



Virtual Ergonomics: Taking Human Factors into Account for Improved Product and Process

Acknowledgements

Authors:

Jerry Fireman, Structured Information
Nancy Lesinski, Lesinski and Associates

Technical Contributors:

Brenton C. Kemmer II, EOS Services Corporation
Julie Charland, Dassault Systèmes Delmia Corp.

Media Contact:

Therese Snow, Dassault Systèmes Delmia Corp.
therese.snow@3ds.com

Virtual Ergonomics: Taking Human Factors into Account for Improved Product and Process

Introduction

Human interaction with products or within designed processes plays a critical role in how well any particular product is accepted by the market or how efficiently any physical system operates. How a human will function in relation to a product or system is difficult to predict, yet ergonomic considerations traditionally have been addressed by intuition or rough calculations. Physical tests are performed long after the product or system can be changed easily or cost effectively. All too often, this results in sub-par designs or massive cost overruns to correct deficiencies overlooked early in the process.

Organizations need a way to accurately and easily simulate the interface between humans and a product or system from the earliest stages of the design and engineering process. Evaluating alternatives from an ergonomic standpoint, when it is inexpensive to change the design, can improve the performance of the product or system, save time and money in the design engineering process, improve manufacturing efficiency and reduce or eliminate the need for costly physical simulations.

Designing for Human Factors: Overcoming the Challenges

Designers are trained to consider the people that will use the products and systems they create. However, designers also have a wide range of other mechanical factors to consider including performance, cost and robustness. Complicating their challenge is the fact that humans don't come in one-size-fits-all configurations. The wide range of human characteristics—proportion, anthropometry, ability, strength—means that ergonomics is often the most difficult variable to factor into the early stages of the design process.

As a result, ergonomic considerations often are not given priority until relatively late in the design process, after many technological choices have been made and changes become difficult and expensive. The result is that products with otherwise exceptional performance often achieve less than expected success in the marketplace because man has to adapt to machine, which may not be the most comfortable experience. Even manufacturing systems that offer major productivity and quality gains may fail at achieving these advantages if workers have difficulty operating and maintaining them. Companies that do install them can experience significantly reduced output and uptime due to these challenges. In extreme cases, workers may even be injured by poor ergonomic design.

The rapidly emerging technology of virtual ergonomics enables designers and engineers to overcome these issues by enabling the simulation of human interaction and ergonomic behavior between a product or system from the earliest stages of the design process. Virtual ergonomic solutions bridge the gap between functional design and design for

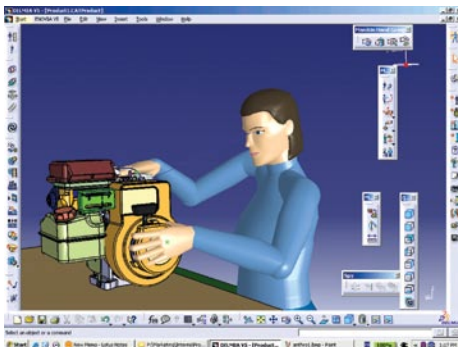

Anthropometry of a female manikin.

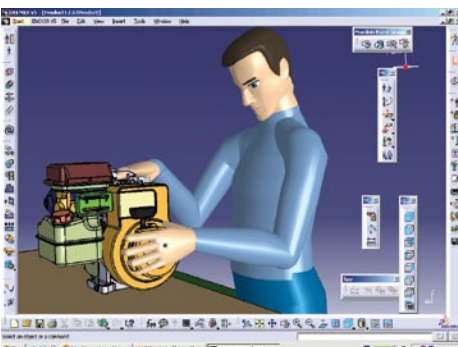

Anthropometry of a male manikin.

human comfort, productivity and safety. They do so by leveraging a comprehensive array of human simulation and ergonomics tools designed specifically for understanding and optimizing the relationship between humans and the products they use or the equipment with which they interact, install, manufacture, operate and maintain.

The best human model simulation tools can address all application domains including product design, manufacturing and maintenance, and enable sharing of human model data between application domains as well. An interface that is common to the existing CAD program is critical in order to reduce the learning curve and optimize return on investment. This allows users to get up and running to deliver major benefits quickly—even when the user is not a trained human factors professional.

Integrating human factors into design

Virtual ergonomics enables users to create and manipulate virtual 3D manikins to investigate the interactions between the consumer or worker and the product. For example, in product design, human factors such as positioning, comfort, visibility, reaching, grasping, ingress, egress, etc., can all be evaluated. Within a manufacturing system environment, work cell layout, workflow throughput, system accessibility, lifting requirements, reaching, etc., can all be predicted. What-if scenarios can be run to optimize product or process design.

Today's advanced software programs with user-friendly interfaces make it easy—even for those not schooled in human factors—to conduct sophisticated human factors studies. For example, simple pulldown menus can be used to create standard 5th, 50th, and 95th percentile male and female manikins. From this, users then have access to sophisticated manikin structures offering 100 independent links and 148 degrees of freedom with limits of joint mobility, permitting precise simulation of actual human capabilities in a wide range of situations.

This new technology also allows users to create advanced user-defined manikins specific to their application within a digital product design and manufacturing simulation using a suite of advanced anthropometry (1) tools. Leading tools can include more than 100 editable anthropometric variables, individual manikin anthropometric customization, a boundary manikin (2) algorithm and Visual Basic scripting for automatic boundary manikin generation.

Virtual ergonomics also offers powerful solutions for defining human activities such as walking, picking, placing, lifting, climbing, and more. Simulated worker manikins can perform activities such as walking to a particular location, ascending and descending stairs or ladders, moving from one posture to another, following the trajectory of a kinematic device or path of an object, or picking up objects and placing them in another location.

Users can comprehensively evaluate all elements of a worker's interaction with products and process. Three-D biomechanics tools calculate torque, load and shear; analyze lifting, lowering and carrying tasks using NIOSH 81 and 91 equations (3); evaluate push and pull

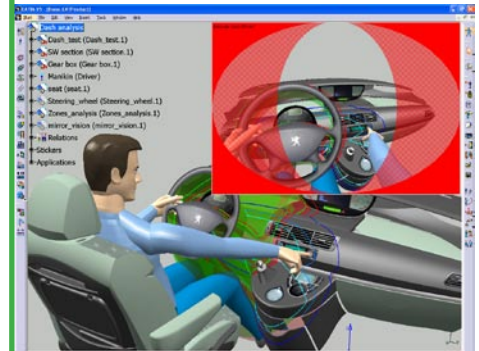

Evaluation of field of vision of a manikin.

tasks using SNOOK and CIRIELLO equations (4); and evaluate RULA (5) for arm position assessment with the ability to customize RULA specifications.

Finally, it becomes easy to qualitatively and quantitatively analyze all aspects of a worker's posture. Whole body and localized postures can be examined, scored and integrated to determine worker comfort, safety, strength, and performance when interacting with a product in accordance with published comfort databases. Static strength can be analyzed, along with comfort and joint analysis and fully articulated pelvic, neck, spine, shoulder and hand models. Without ever incurring the high cost of a physical prototype or real-world mockup, it becomes possible to reliably predict how humans and machines will interact in the real world and the stresses that each will experience.

Virtual Ergonomics: The Advantages of Integration

When virtual ergonomics are integrated within a leading 3D CAD and digital manufacturing environment, users gain the ability to perform comprehensive ergonomic simulations at any stage of product or process development. The best integrations allow users to work directly in their environment while maintaining complete associativity between the design and the manikin. A modular approach to human modeling provides a scalable solution that makes it possible to start with an entry level solution and move up to a more advanced solution later, or to deploy differing solutions to various users based on their needs and skills. Users also should be able to define and store customized manikins for reuse, as well as save and re-apply simulation specifications.

This new approach requires an extraordinarily broad set of ergonomic simulations. Users should be able to quickly take into account the special characteristics of target populations, assess manikin vision, examine and score body postures and optimize operator comfort in complete accordance with standard industry rules. An independent TNO (Netherlands Organization for Applied Research)/Air Force Research Laboratory validation study, for example, showed that a DELMIA virtual manikin provides 94% fidelity compared to a real subject, in contrast to 64% to 80% fidelity for the four other main competitors in this space.

Virtual ergonomics business benefits

Companies that evaluate human interactions early in their product design process generally realize four profound business benefits:

- **Improved product usability:** The performance and customer acceptance of a wide range of products can be greatly improved by simplifying the process of designing these products for use by human beings. Designers can consider ergonomics early in the design process by considering many alternatives from a human factors standpoint, helping them determine which alternatives deserve further consideration.
- **More efficient design process:** In addition to improving the performance of the product, virtual ergonomic simulation can reduce engineering leadtime and cost by getting the ergonomic design right the first time and avoiding the need to go back and make changes later, when they will be more difficult and expensive.



Exit head clearance evaluation.

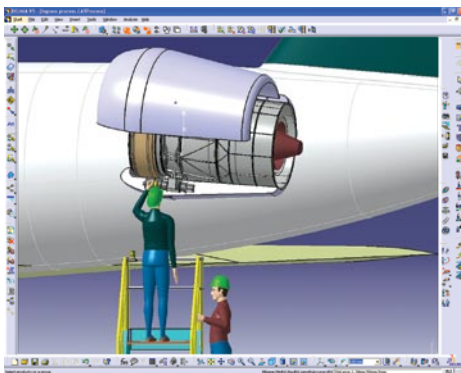

Engine maintenance.

- **Reduced workplace injuries:** Companies that manufacture products or produce manufacturing equipment need to consider the effects of ergonomics to avoid workplace injuries, increase manufacturing throughput and productivity, and improve quality. According to the U.S. Bureau of Labor and Statistics, U.S. employers spend more than \$7.4 billion in workers compensation costs, and untold billions more on medical treatment, litigation costs, hidden costs and lost productivity.”

Simulation of human factors can lower the cost of work-related injuries by introducing ergonomics earlier in the design process. Ergonomic simulation can be used to evaluate a work cell or other manufacturing process to evaluate the interaction between the human model and the work environment such as reach analysis or posture requirements. Virtual workplaces can be evaluated against industry standards such as NIOSH, Snook, Ciriello and RULA to identify any potential for injury so that corrections can be made long before equipment is ordered. A wide range of manikins can be used in the simulation to determine how different types of people will interact with the work cell. As an example, tools can be designed or arranged so that shorter workers do not have to reach above shoulder level, while taller workers do not have to reach below their waist.

- **Increased manufacturing throughput and quality:**

Virtual ergonomic processes also can be used to increase the cycle time or throughput of a manufacturing process. For example, the time required and energy expended by operators to perform various operations can be evaluated so that productivity increases without increasing the operator’s workload. Before anything is built or even ordered in the physical world, the virtual workplace can easily be modified by reconfiguring the workcell layout, tooling and equipment to optimize the worker’s motions. By viewing a simulation of the manufacturing process long before tooling has been ordered, engineering and manufacturing staff can identify changes in the tooling and equipment that improve productivity and quality.

Ergonomic simulation may enable quality improvements by identifying situations where the operator may be overloaded and unable to oversee all operations within his domain. Problems that should be quickly identified and corrected may then be overlooked. Identifying these situations at an early stage in the process development makes it possible for them to be corrected at little or no cost. This also helps to improve quality by ensuring that workers can assemble heavy, awkward or expensive parts without damaging them and use the specified tool without concerns such as reachability or vision.

Reduced dependence on physical prototypes and real-world simulations:

Today, physical mockups or prototypes are often the primary method of evaluating the ergonomics of a product or assembly process. Physical mockups can be very expensive to build because they often require purchase of assembly line components, tooling, and building prototype parts. Additionally, physical prototypes cannot occur until the later stages of the design process when changes can be very expensive.

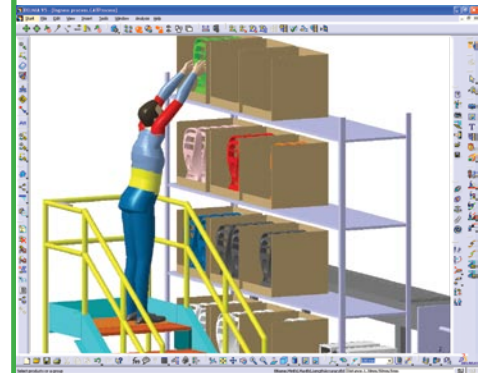

Analysis of worker posture and reach analysis.

Simulating human interaction with software prototypes makes it possible to reduce or eliminate the need for mockups and physical prototypes. Various design alternatives can be evaluated at an earlier stage in the design process to optimize the design to a higher level than is possible with physical mockups. The physical mockup, if it is still needed, can be used to validate the optimized design. And with simulation methodology, the physical prototype that is produced will be much closer in final representation to the production model.

Real-world Examples

To better understand how advanced virtual ergonomic tools and processes can improve design and manufacturing efficiency while reducing or eliminating the need for physical simulations and reducing workplace injuries, let's consider actual examples of the technology at work, courtesy of DELMIA.

Product Design: Whirlpool India

Consultants used DELMIA Human (6) to optimize a washing machine design for Indian consumers based on accessibility, vision and comfort. Prior to the launch of a new line of vertical axis automatic washing machines, Whirlpool India wanted to be sure that Indian consumers would be able to comfortably see into, reach into, and unload the damp clothes lying at the bottom of the washing tub after the wash cycle was completed.

“We wanted to be sure, before launching a newly designed washing machine, that it would be appropriate for the Indian consumer,” said B. Venkatesan, Sr. Manager – RTC of Whirlpool India. “The only way to do this at the design stage, without making numerous prototypes, was to perform an accurate digital ergonomic simulation.” Whirlpool India also wanted to ensure that the machines were easy to service and that the maintenance manuals were self-explanatory.

DELMIA India consultants performed an ergonomic product design study using the DELMIA Human technology. Human population and anthropomorphic data built into the DELMIA solution was used to test the design of the product using the digital manikin based on an average member of India's population. Four proposed designs were evaluated based on accessibility, vision and comfort. The results of the study were used to select the design best suited for the Indian market.

After the success of this study, DELMIA Human was used to perform maintainability studies on two horizontal-axis washing machines. The goal was to optimize the assembly and disassembly process that should be followed when servicing the new washing machine models. The unique automatic documentation generation feature within the solution enabled Whirlpool to leverage the completed analysis to communicate effectively to service personnel by graphically illustrating the maintenance processes.

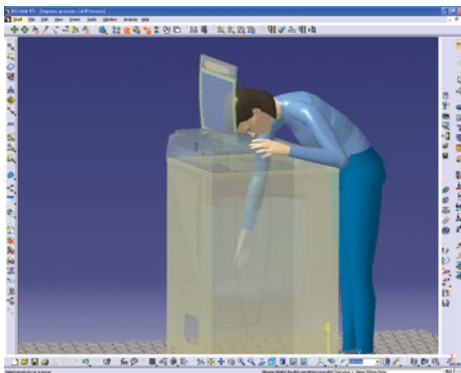

Washing machine design optimization.

Manufacturing Process: Northrop Grumman

At \$200 billion, the F-35 or Joint Strike Fighter is the Pentagon's biggest-ever procurement package. As a subcontractor to Lockheed Martin Corp., the Integrated Systems Sector of Northrop Grumman Corporation (NGC) was chosen to design and build the center fuselage, located between the rear bulkhead of the cockpit and the wing.

Tasks of the production workers at NGC must be synchronized, sometimes with the precision of a ballet, to build one center fuselage per day. Workstations must be designed to protect the mechanics from injuries ranging from repetitive stresses and awkward or painful reaches to head bumps.

NGC is leveraging DELMIA solutions to optimize the process before the tooling is fabricated and the manufacturing process finalized. According to Manufacturing Engineering Manager Mike North, NGC's Air Combat Systems unit is realizing \$1 million in savings every year on a one-time \$200,000 investment in digital ergonomics and manufacturing.

Manufacturing Process: Volkswagen

Volkswagen has recognized the productivity increasing effects of an optimized workstation and has appointed an engineer to improve the interface between man and machine. Maileen Zander serves as a consultant for Volkswagen's various vehicle projects in all matters pertaining to workstation ergonomics. As soon as Zander receives a department's request to optimize a workstation, she analyzes the existing work environment using pre-defined criteria.

Given that employees' task procedures are often complex, she relies upon DELMIA V5 Human software, which enables her to create the 3D manikins. "DELMIA V5 Human gives me the capability to first simulate work environments on the computer and to check their suitability before we implement them in real life," said Zander. "The alternative would be to first change the work environment and then check whether the results actually reflect the desired improvements. DELMIA V5 Human is an absolutely essential tool for my work. Without the true-to-life simulation, we would be unable to verify our findings in the early planning phase."

Maintenance: San Onofre Nuclear Generating Station

San Onofre Nuclear Generating Station (SONGS) is the largest generator of electricity in Southern California, serving 2.75 million homes with 20 percent of the total power supplied by Southern California Edison (SCE). SONGS officials were among the first in the nation to recognize that, due to normal thermal growth that the plant's thimble rods which carry performance data to the control room from deep inside the nuclear core, no longer fit as they did when the plant was new. Since the rods are radioactive and submerged in a pool of water, replacing them required the use of divers who can only work in limited shifts to manage their radiation exposure. Ensuring the safety of the divers, combined with the US \$1 million per day cost of purchasing replacement power while the plant was out of commission, required flawless execution of the project. CATIA and DELMIA Human were used to create digital models of SONGS' facilities, which were then used to simulate the human activities involved in replacing the thimble rods.



Optimization of an automotive workstation.

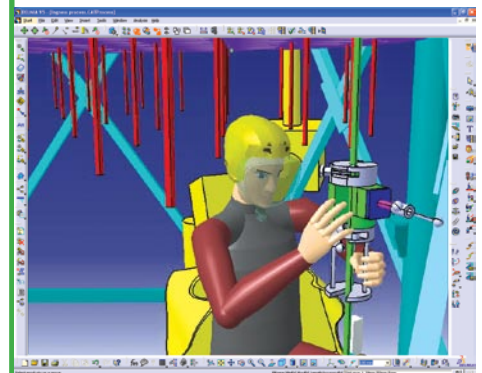

Nuclear generator diver analysis.

This allowed designers to bring time and motion studies into the product planning. Simulating a diver cutting the thimble rods allowed SONGS to validate the use of DELMIA tools for planning procedures, schedules, and budgets. Additionally, SONGS was able to see how the tools could identify potential roadblocks that might be encountered when replacing the thimble rods and moving the generators—from cutting a hole through 4-foot-thick (1.2 meter) concrete to gain access to the units, to relocating the massive numbers of electrical cables that cross the space where the hole will be cut.

Conclusion

The capabilities of proven virtual ergonomic solutions such as these provided by DELMIA make it easy to embed digital humans into product design, manufacturing, maintenance and training simulations. And, accuracy is so great that the need for physical prototypes and real-world mockups can be greatly reduced or even eliminated. Product designers can evaluate many different design alternatives in the early stages of the product development in order to make substantial design improvements from an ergonomic standpoint. Manufacturing engineers can consider human factors' impact as well as limitations affecting the manufacturing process at a much earlier stage, ensuring worker safety and improving productivity. Products and processes can be completed faster and at a lower cost because the ability to evaluate human factors in the virtual environment greatly reduces the likelihood of design changes being required later in the development cycle. And, because the knowledge is accessible through the CAD interface, there is a quick learning curve for the engineer to factor human considerations into the production equation.

“To succeed in today’s tough competitive environment, manufacturing companies need to design more ergonomic products and safer, more productive workplaces,” said Dick Slansky, Senior Analyst PLM & Discrete Manufacturing for the ARC Advisory Group. “At the same time, products need to be launched in less time and at a lower cost. Virtual ergonomics helps companies achieve these goals and is becoming mandatory in today’s competitive manufacturing environment.”

For more information on virtual ergonomic solutions with DELMIA, please send an e-mail to info@delmia.com or call 800.382.3342 to speak with a solution specialist.

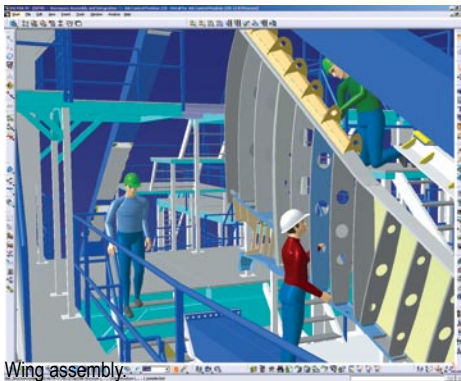

Wing assembly

GLOSSARY

- (1) refers to the measurement of the human individual for the purposes of understanding human physical variation.
- (2) refers to manikins that are at the boundaries of the population that the product is designed to accommodate such as a 5% manikin or a 95% manikin.
- (3) National Institute of Occupational Safety and Health: measures the effects of lifting/lowering and carrying to fully optimize task performance.
- (4) measures the effects of carrying/pushing/pulling to fully optimize task performance.
- (5) Rapid Upper Limb Assessment: ergonomic screening tool and survey method for determining posture, force, and frequency concerns with focus on the neck, upper limbs, and trunk.
- (6) a powerful digital human modeling tool to create, validate and simulate human worker interaction for manufacturing

AMERICAS
Dassault Systèmes Delmia Corp.
900 N. Squirrel Road - Suite 100
Auburn Hills, MI 48326 USA
Tel.: +1 248 267 9696
Fax: +1 248 267 8585

Dassault Systèmes/Safework Inc.
393 St - Jacques West - Suite 300
Montreal, Quebec H2Y 1N9
CANADA
Tel: 514 931 3000
Fax: 514 931 2118

DELMIA EUROPE
DELMIA France
10, Rue Marcel Dassault
78140 Vélizy-Villacoublay, FRANCE
Tel.: +33 1 61 62 61 62
Fax: +33 1 70 73 43 63

DELMIA GmbH
Raiffeisenplatz 4 - 70736 Fellbach
GERMANY
Tel.: +49 711 / 2 73 00 - 0
Fax: +49 711 / 2 73 00 - 599

DELMIA Division of Dassault Systèmes S.r.l.
Str. Torino, 43 - Orbassano (TO) -
10043 - ITALY
Tel.: +39 011 9040703
Fax: +39 011 9040762

DASSAULT SYSTEMES AB
Lindholmospiren 5
SE - 417 56 Göteborg SWEDEN
Tel.: +46 (0) 31 720 58 35
Fax.: +46 (0) 31 89 96 25

DELMIA Ltd
Dassault Systèmes
9 Riley Court, Milburn Hill Road
Coventry CV4 7HP
UNITED KINGDOM
Tel.: +44 24 76 85 74 00
Fax: +44 24 76 85 74 02

DELMIA ASIA-PACIFIC
DELMIA Solutions Private Limited
680, 8th Main JP Nagar, 2nd Phase
Bangalore 560 078 INDIA
Tel.: +91 80 6589858 / 59
Fax: +91 80 6589855

DELMIA Japan Ltd
Shin - Yokohama Mineta Building,
9F, 2 - 3 - 19, Shin - Yokohama,
Kouhoku - ku, Yokohama - shi,
Kanagawa - ken, 222 - 0033
JAPAN
Tel.: +81 45 470 8282
Fax: +81 45 470 8283

Dassault Systèmes Offices
representing DELMIA
Dassault Systèmes Argentina
Av Alicia Moreau de Justo 740 1er
piso of. 2 - Puerto Madero, Buenos
Aires (C1107AAR) - ARGENTINA
Tel.: +54 11 4345 2360
Fax: +54 11 4345 2361

Dassault Systèmes do Brasil Ltda.
Rua Cantagalo, 74, 7 andar, sl 708
Tatuapé, São Paulo - SP / BRASIL
Cep: 03319-000
Tel.: +55 11 6191 6581
Fax: +55 11 6192 2759

Dassault Systèmes
Korea Competency Center
Kumho Bldg 12F 416 Mapo - Dong
Mapo - Ku Seoul, KOREA
Tel.: +82 2 3270 7800
Fax: +82 2 702 7050

Dassault Systèmes de Mexico
Pennsylvania No 4 Piso 2
Col. Napoles, MEXICO DF 03810
Tel.: +52 55 5536 9697
Fax: +52 55 5536 9697 ext. 21
Fax: +52 55 5536 9697 ext. 21

DS China
Unit 6-Unit 8, 8F AZIA Center
133 North of Ying Cheng Road
Lujiazui Pudong
200120 SHANGHAI, China
Tel: +86 21 5888 0101

DSKK China
Room 707-709
Tower 2
China Central Place
No.79, Jianguo Road
Chaoyang District
100025 BEIJING, China
Tel: +86 10 6536 2288

DSKK SGP Rep.Office
7 Temasek Boulevard #22-03A
Suntec Tower One
038987, Singapore
Tel: +65 6511 1500

DSKK Taiwan
Room 607, No.205
Tun Hwa N. Rd.
Taipei 105, Taiwan
Tel: +886 2 2718 0286

DSKK Taiwan, 16th Floor B
530 Yin-Chai Road
Taichung 403, Taiwan
Tel: +886 4 2302 6996

About Dassault Systèmes

As a world leader in 3D and Product Lifecycle Management (PLM) solutions, Dassault Systèmes brings value to more than 100,000 customers in 80 countries. A pioneer in the 3D software market since 1981, Dassault Systèmes develops and markets PLM application software and services that support industrial processes and provide a 3D vision of the entire lifecycle of products from conception to maintenance to recycling. The Dassault Systèmes portfolio consists of CATIA for designing the virtual product - SolidWorks for 3D mechanical design - DELMIA for virtual production - SIMULIA for virtual testing - ENOVIA for global collaborative lifecycle management, and 3DVIA for online 3D lifelike experiences. Dassault Systèmes' shares are listed on Euronext Paris (#13065, DSY.PA) and Dassault Systèmes' ADRs may be traded on the US Over-The-Counter (OTC) market (DASTY). For more information, visit <http://www.3ds.com>.

CATIA, DELMIA, ENOVIA, SIMULIA, SolidWorks and 3D VIA are registered trademarks of Dassault Systèmes or its subsidiaries in the US and/or other countries.

